

DF

Dual-Fuel Engines

DE20DF DE23DF

DE28DF DE35DF

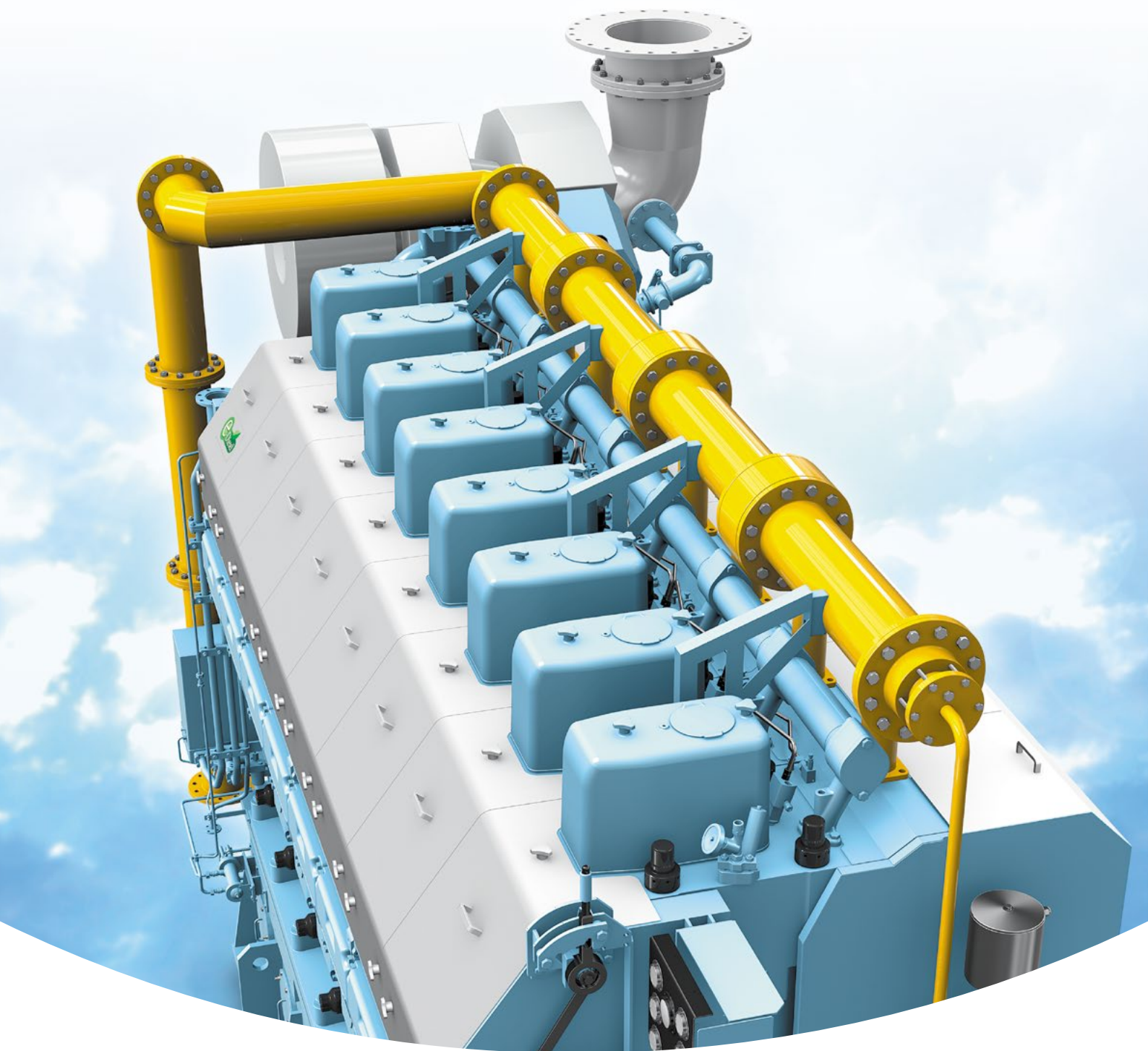

DAIHATSU

InfiniEarth

High Environmental Performance through Precise and Detailed Control

Dual-fuel engines that operate on both environmentally friendly natural gas and conventional petroleum fuel require precise control and must offer high safety and durability. We have incorporated the results of extensive research on the internal combustion engine into the development of our dual-fuel engines.

Our dual-fuel engines offer accurate and stable operation on natural gas while incorporating the excellent environmental performance inherited from the company's diesel engines, which boast features such as a fuel injection system with high control precision, superb fuel efficiency, and outstanding engine durability.

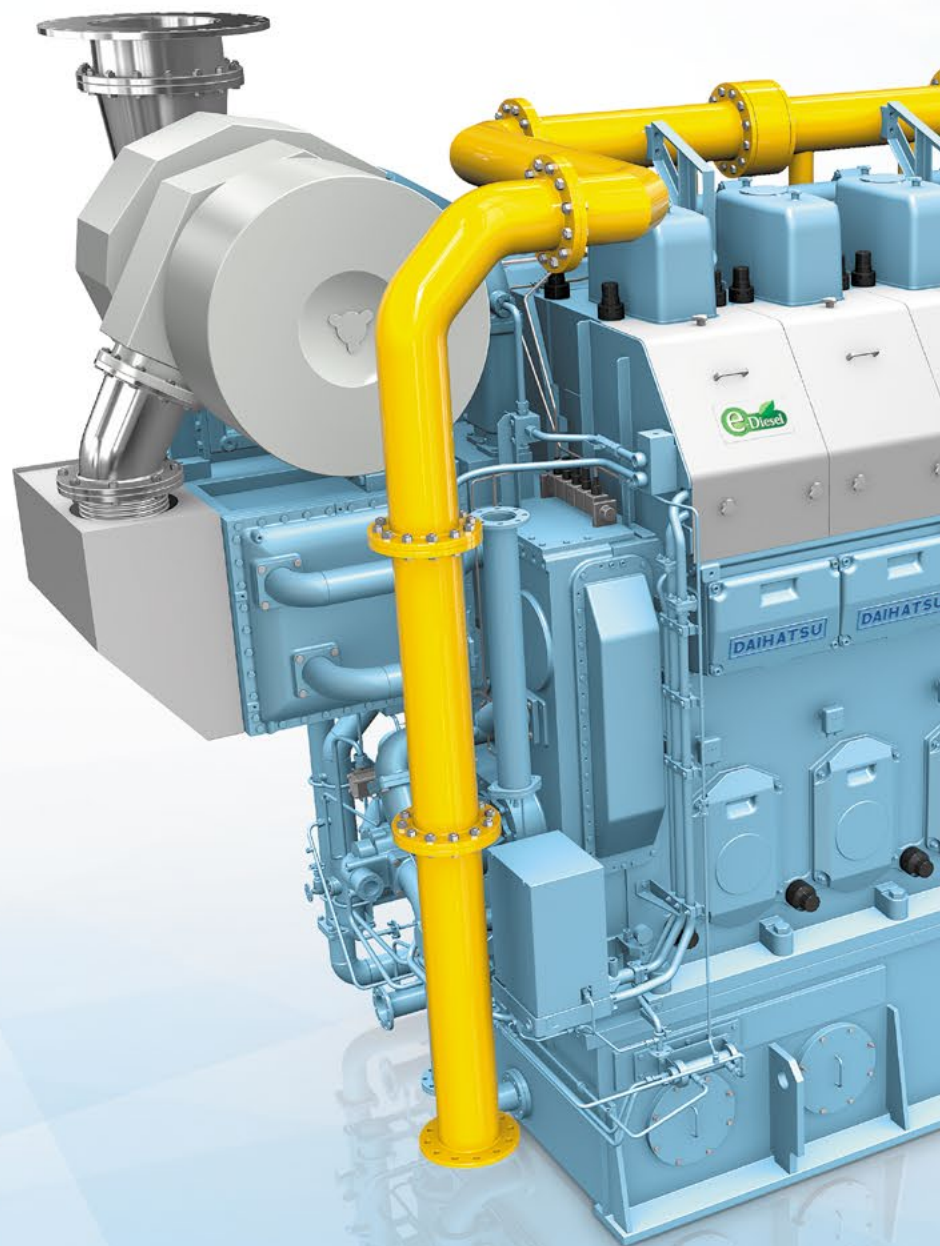

DF | Dual-Fuel Engines
DE20DF DE23DF
DE28DF DE35DF



Type approval certificate

Compliance with NOx Tier III standards in gas mode and Tier II standards in diesel mode

Our dual-fuel engines comply with the IMO NOx Tier III standards when running in gas mode and with the Tier II standards when running in diesel mode. The operating mode can be switched as needed, such as when navigating on a sea where clean engine operation is required or when there is a fuel procurement issue. They can operate in the most suitable mode according to the situation.

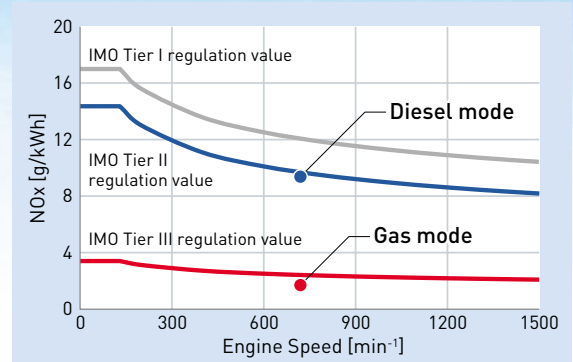

No change to engine rotation speed when switching to gas mode or diesel mode

Advanced fuel injection control ensures a smooth switchover to gas mode or diesel mode without changing the engine rotation speed. This eliminates any output interruption when switching modes.

Diesel mode → Gas mode

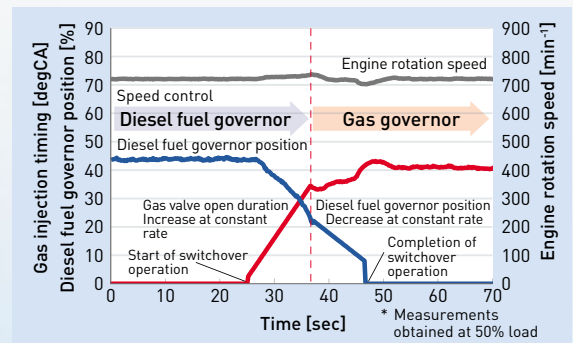

Gas mode → Diesel mode

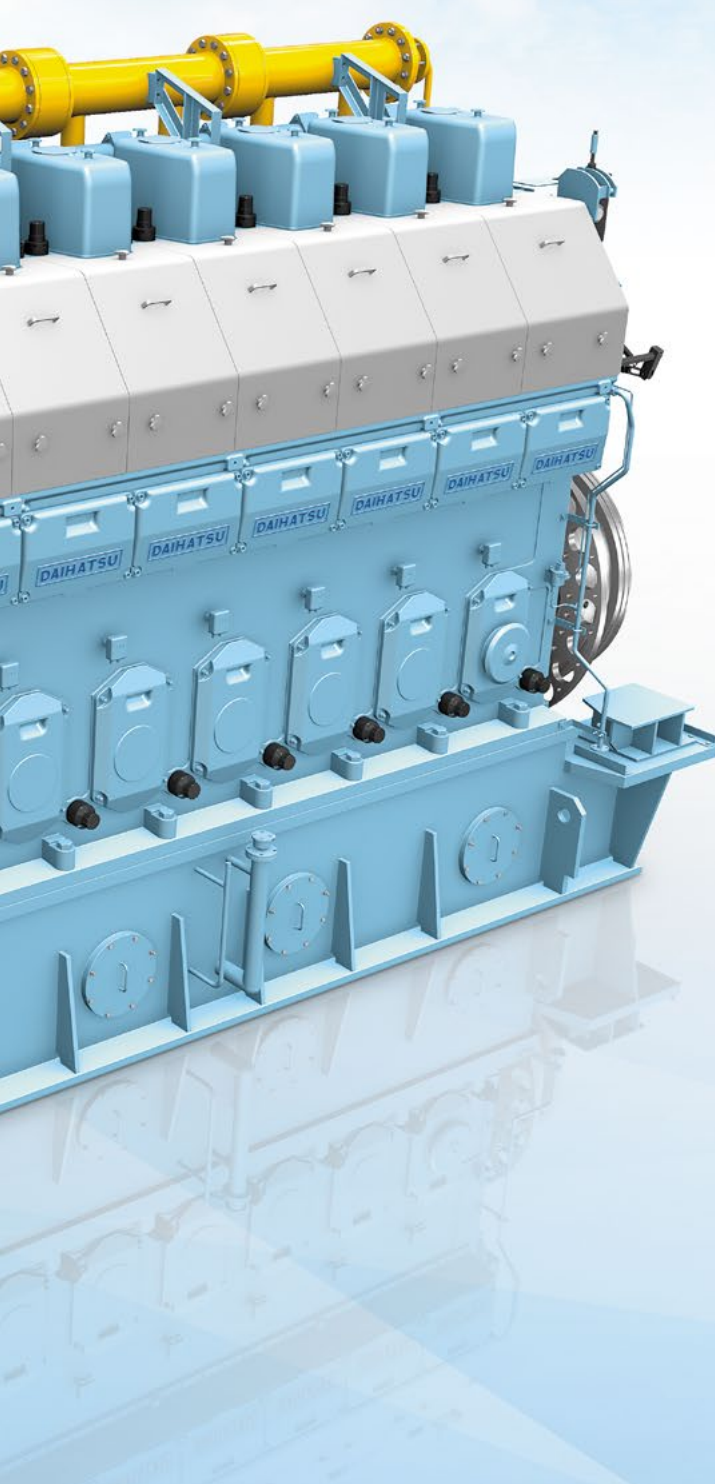
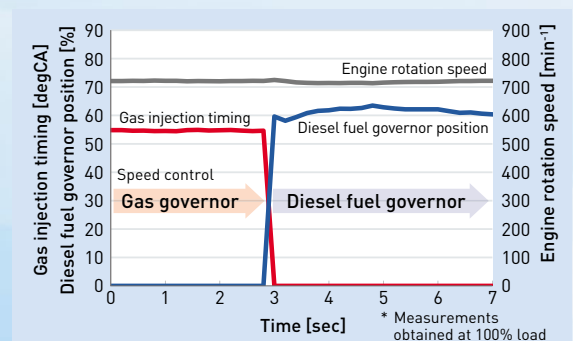

Sophisticated Technologies Behind High Efficiency

Technologies that have been accumulated through the development of diesel engines were applied to develop the gas combustion system.

High-efficiency combustion is ensured in both gas mode and diesel mode operation.

Accurate fuel injection using a common rail

A common rail system is used for the pilot fuel injection. A precise amount of high-pressure fuel is injected at the optimal timing according to the operating condition, thus helping to improve fuel economy and reduce NOx.



Twin nozzles

Using the two injection devices, the main nozzle and pilot nozzle, the valve train control system achieves optimal and precise operation in each cycle, thus attaining high combustion efficiency.

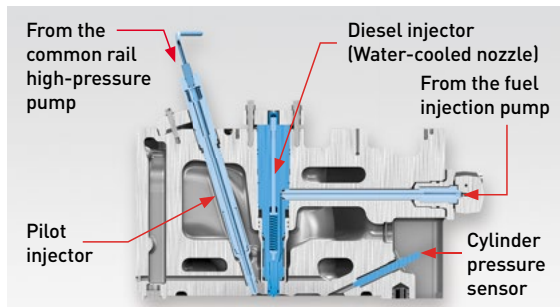



Compatible with various types of fuels

Gas mode	99% Natural gas
	1% MDO/MGO (pilot fuel)
Diesel mode	97% MDO/MGO/HFO
	3% MDO/MGO (injector cooling)

Gas pipe featuring a double-walled structure

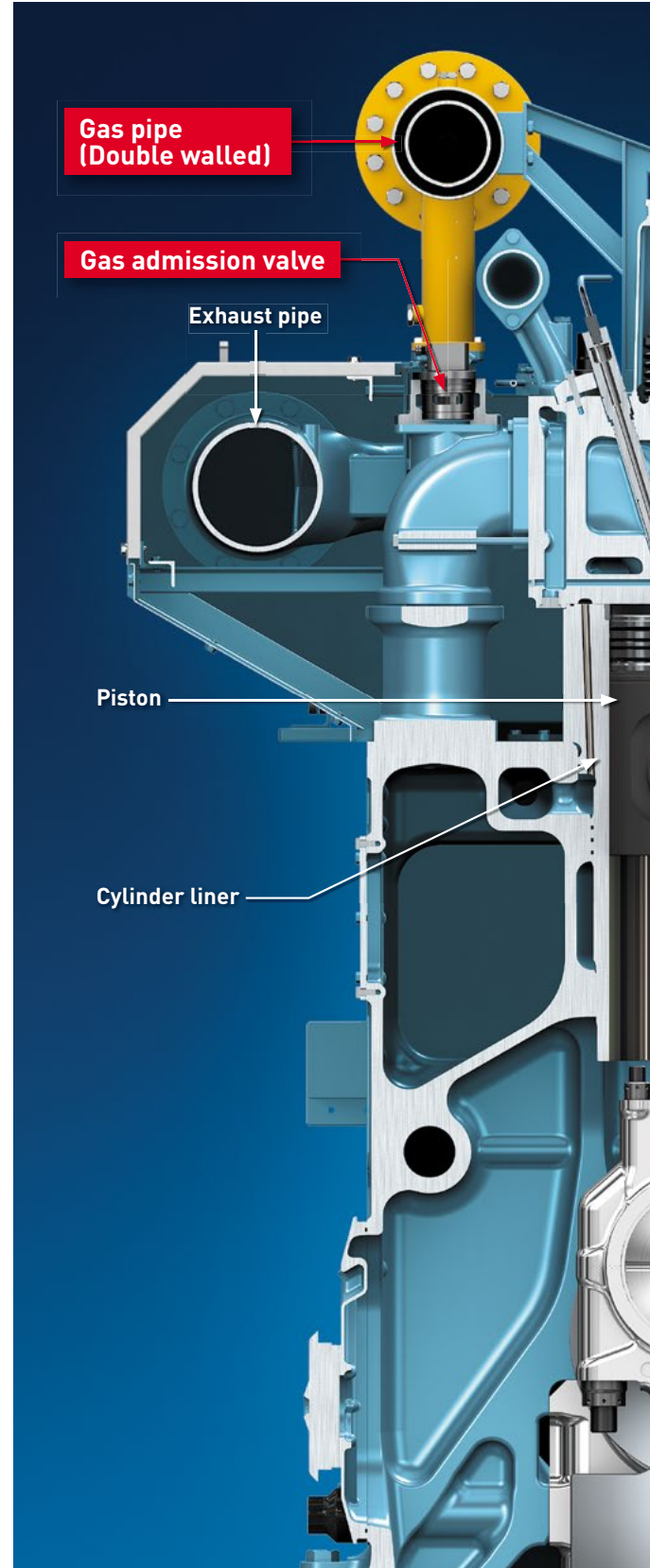
The gas pipe features a double-walled structure for extra safety.



* The parts indicated with the red background [] are modified from existing parts of conventional diesel engines.

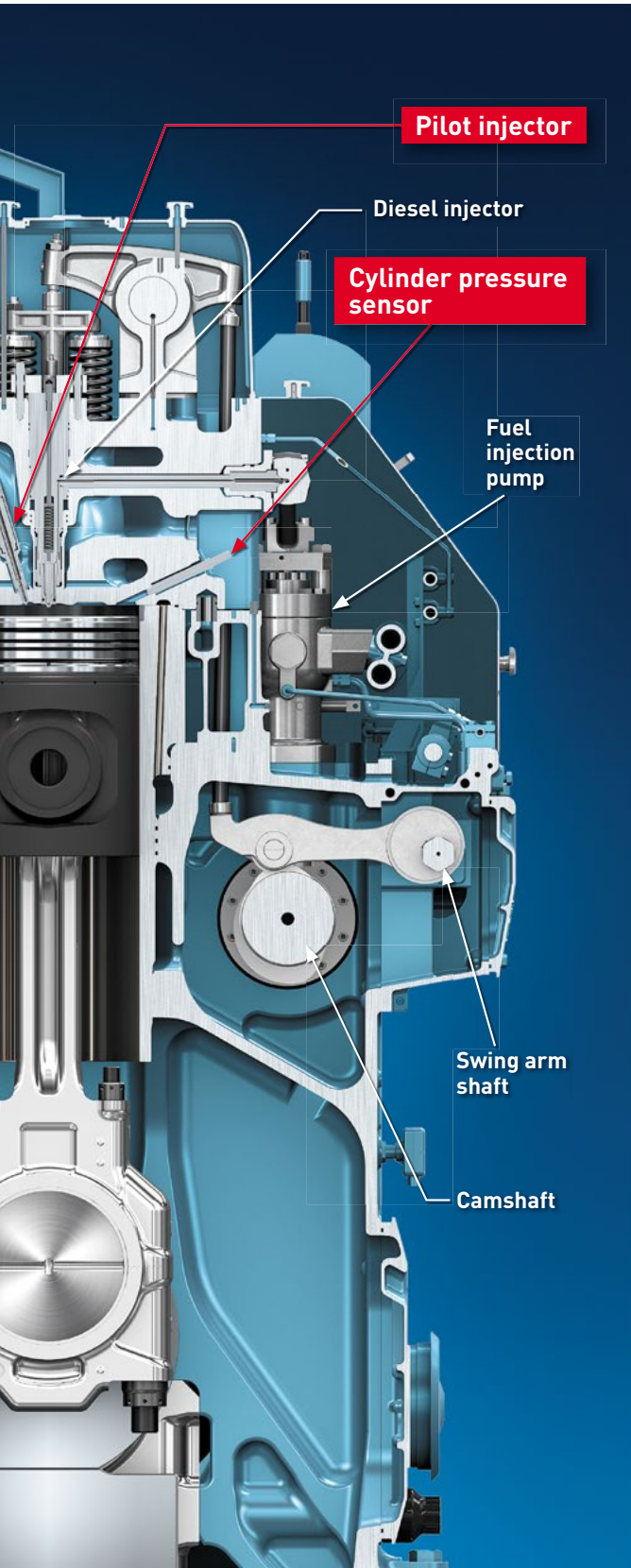

designed exclusively for the DF engine; other parts are

Variable valve timing mechanism

The valve train control system incorporates a variable valve timing mechanism. The system optimally controls the timing of the valve opening and closing according to the engine speed and load, thus helping to suppress NOx emission and improve anti-knocking performance. It also provides control to provide stable output at startup and during low-load operation.

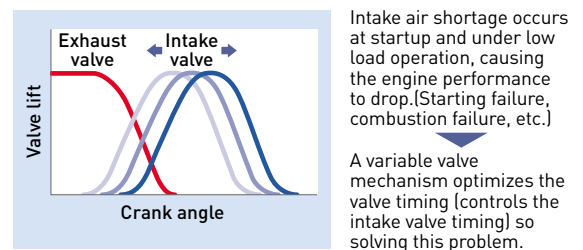
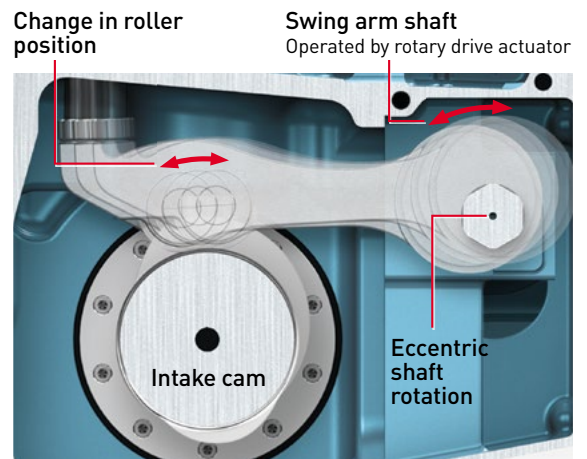

Four-stage load input for super load response

Each system is optimally controlled to increase the load from startup to maximum load in four stages in gas mode. This achieves quick increase of the engine speed to the usable range.

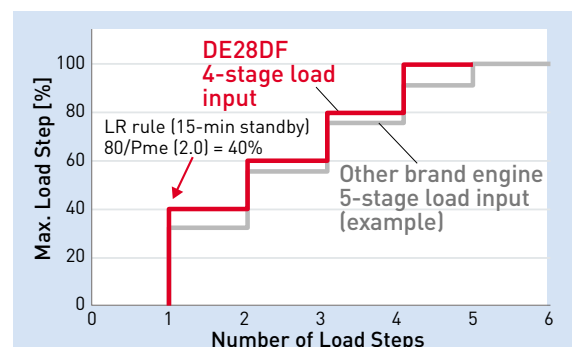

External View

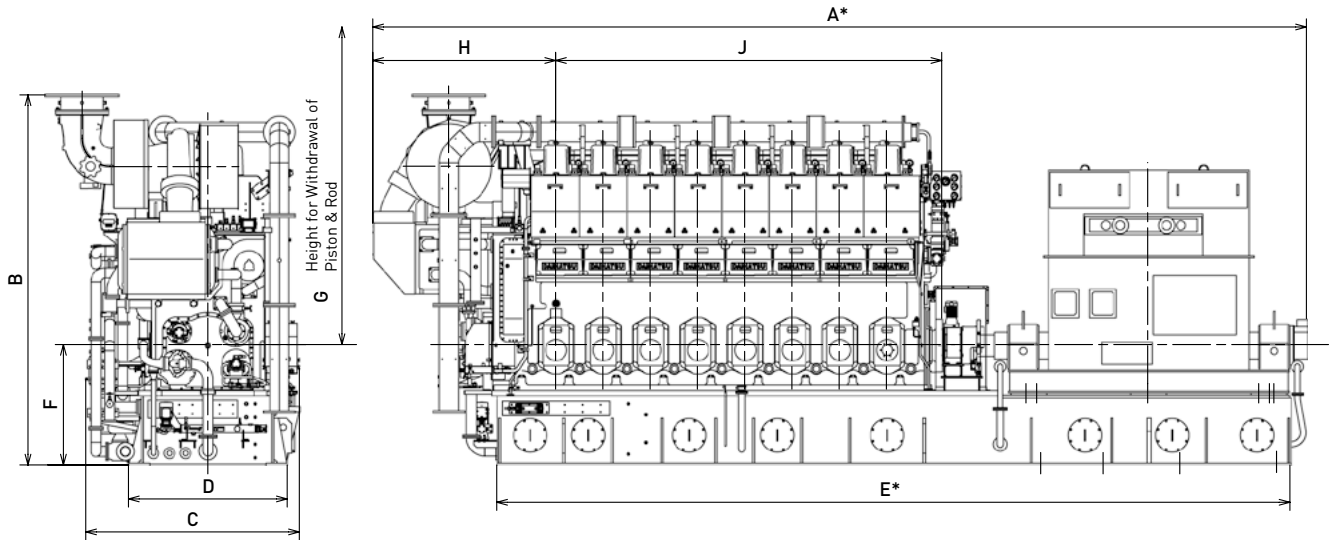

8DE35DF

Dimensions and Mass

Model	Dimensions (mm)									Dry mass* (ton)
	A	B	C	D	E	F	G	H	J	
6DE20DF	5510	3245	1830	1040	4290	1000	1530	1240	2035	20
6DE23DF	6000	3150	2200	1170	4600	1150	1720	1460	2300	27
6DE28DF	7190	3645	2230	1380	5600	1300	2065	2020	2580	40
6DE35DF	9065	3950	2570	1780	7460	1350	2555	2050	3270	81
8DE35DF	10470	4150	2570	1780	8895	1350	2555	2050	4330	98

* Actual dimensions and mass may vary depending on the specifications of the generator unit.

Main Specifications

Engine model		6DE20DF	6DE23DF	6DE28DF	6DE35DF	8DE35DF
Bore x Stroke	mm	Φ205×300	Φ230×320	Φ280×390	Φ350×440	
Number of cylinders	-	6	6	6	6	8
Rotation speed	min ⁻¹	900	900	720	720	
Maximum engine output	kWm	890	1,200	1,730	3,060	4,080
Maximum generator output	kWe	840	1,140	1,640	2,950	3,940
NOx emission rate	-	≤ Tier III (gas mode) ≤ Tier II (diesel mode)				
Fuel	-	Natural gas (gas mode) MDO, MGO, (HFO) (diesel mode)				
Pilot fuel	-	MDO or MGO				



Backed by R&D that takes marine use into full consideration, our dual-fuel engines continue evolving.

At Daihatsu's Moriyama Factory, we take onboard installation into full consideration in the research and development of marine engines. Through the R&D process, our dual-fuel engines have been refined and cleared various issues that they might encounter in actual usage. We spare no effort in R&D. For example, we have constructed a natural gas supply facility on the premises of the factory for the research and development of fuel supply and storage equipment. We continue to make our products safer and more reliable.

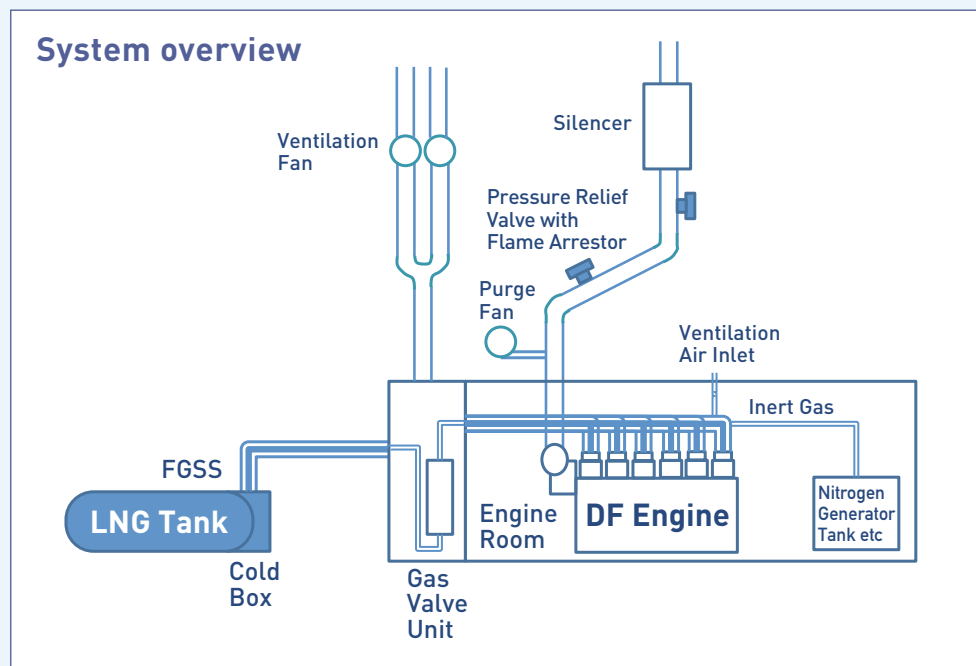



DAIHATSU INFINEARTH MFG. CO., LTD.

Head Office

1-30, Oyodo Naka 1-chome, Kita-ku, Osaka 531-0076, Japan
Phone: +81-6-6454-2340 Fax: +81-6-6454-2686

Moriyama Division

45 Amura-cho, Moriyama-city, Shiga 524-0035, Japan
Phone: +81-77-583-2551 Fax: +81-77-582-5714

Tokyo Office

2-10, Nihonbashi-Honcho 2-chome, Chuo-ku, Tokyo
103-0023, Japan
Phone: +81-3-3279-0821 Fax: +81-3-3245-0359

DAIHATSU INFINEARTH HIMEJI MFG. CO., LTD.

12-8, Fuji-cho, Hirohata-ku, Himeji-city, Hyogo 671-1123, Japan

DAIHATSU INFINEARTH (EUROPE) LTD.

FORA Borough Yards, 13 Dirty Lane, London, SE1 9PA, U.K.
Phone: +44-20-4566-5600

DAIHATSU INFINEARTH (ASIA PACIFIC) PTE. LTD.

16 Collyer Quay, #29-02 Collyer Quay Centre 049318,
Singapore
Phone: +65-6589-9510 Fax: +65-6536-4964

DAIHATSU INFINEARTH (AMERICA), INC.

380 N Broadway, Suite 302 Jericho, N.Y. 11753, U.S.A.
Phone: +1-516-822-3483 Fax: +1-516-822-3485

DAIHATSU INFINEARTH (SHANGHAI) CO., LTD.

Room A-B, Floor 14, Huamin-Empire-Plaza, No.728,
Yanan Rd.(W.), Shanghai, China
Phone: +86-21-6225-7876 Fax: +86-21-6225-9299



www.d-infi.com

• All information contained in this pamphlet is correct at the time of printing, but may be subject to change without notice.